



Logic-Based Modeling and Solution of Nonlinear Discrete/Continuous Optimization Problems

SANGBUM LEE

IGNACIO E. GROSSMANN *

grossmann@cmu.edu

Department of Chemical Engineering, Carnegie Mellon University, Pittsburgh, PA15213

Abstract. This paper presents a review of advances in the mathematical programming approach to discrete/continuous optimization problems. We first present a brief review of MILP and MINLP for the case when these problems are modeled with algebraic equations and inequalities. Since algebraic representations have some limitations such as difficulty of formulation and numerical singularities for the nonlinear case, we consider logic-based modeling as an alternative approach, particularly Generalized Disjunctive Programming (GDP), which the authors have extensively investigated over the last few years. Solution strategies for GDP models are reviewed, including the continuous relaxation of the disjunctive constraints. Also, we briefly review a hybrid model that integrates disjunctive programming and mixed-integer programming. Finally, the global optimization of nonconvex GDP problems is discussed through a two-level branch and bound procedure.

Keywords: mixed-integer programming, generalized disjunctive programming, global optimization, logic-based programming

1. Introduction

The mathematical programming approach to discrete/continuous optimization problems has been widely used in operations research and engineering. For example, the applications are in process design and synthesis, planning and scheduling, process control, and recently, in bioinformatics. Over the last decades, there has been a significant progress in the development of the discrete/continuous optimization models and their solution algorithms. For a recent review in the applications to the process systems engineering, see Grossmann, Caballero, and Yeomans (1999). It is the objective of this paper to present an overview of the major advances in the mathematical programming techniques for the modeling and solution of discrete/continuous optimization problems. This paper is organized as follows. First, the modeling formulations and their solution strategies are presented. We then briefly review the continuous relaxation of discrete/continuous models. Finally, a global optimization method of nonconvex problems will be presented. Also, the possibilities of the hybrid model of mixed-integer program and disjunctive program are discussed.

*Corresponding author.

2. Review of mixed integer optimization

The conventional way of modeling discrete/continuous optimization problems has been through the use of 0-1 and continuous variables, and algebraic equations and inequalities. For the case of linear functions this model corresponds to a mixed-integer linear programming (MILP) model, which has the following general form,

$$\begin{aligned} \min Z &= a^T y + b^T x \\ \text{s.t. } Ay + Bx &\leq d \\ x &\in R^n, \quad y \in \{0, 1\}^m \end{aligned} \tag{MILP}$$

In problem (MILP) the variables x are continuous, and y are discrete variables, which generally are binary variables. As is well known, problem (MILP) is NP-hard. Nevertheless, an interesting theoretical result is that it is possible to transform it into an LP with the convexification procedures proposed by Lovacz and Schrijver (1991), Sherali and Adams (1990), and Balas, Ceria, and Cornuejols (1993). These procedures consist in sequentially lifting the original relaxed x - y space into higher dimension and projecting it back to the original space so as to yield after a finite number of steps the integer convex hull. Since the number of operations required is exponential, these procedures are only of theoretical interest, although they can be used as a basis for deriving cutting planes (e.g. lift and project method by Balas, Ceria and Cornuejols 1993).

As for the solution of problem (MILP), it should be noted that this problem becomes an LP problem when the binary variables are relaxed as continuous variables, $0 \leq y \leq 1$. The most common solution algorithms for problem (MILP) are LP-based branch and bound methods, which are enumeration methods that solve LP subproblems at each node of the search tree. This technique was initially conceived by Land and Doig (1960), Balas (1965), and later formalized by Dakin (1965). Cutting plane techniques, which were initially proposed by Gomory (1958), and consist of successively generating valid inequalities that are added to the relaxed LP, have received renewed interest through the works of Crowder, Johnson, and Padberg (1983), Van Roy and Wolsey (1986), and especially the lift and project method of Balas, Ceria, and Cornuejols (1993). A recent review of branch and cut methods can be found in Johnson, Nemhauser and Savelsbergh (2000). Finally, Benders decomposition (Benders, 1962) is another technique for solving MILPs in which the problem is successively decomposed into LP subproblems for fixed 0-1 and a master problem for updating the binary variables.

The software for MILP solver includes, for example, OSL, CPLEX and XPRESS which use the LP-based branch and bound algorithm combined with cutting plane techniques. Mixed-integer linear programming (MILP) models and solution algorithms have been developed and applied to many industrial problems successfully (Nemhauser and Wolsey, 1988; Kallrath, 2000).

For the case of nonlinear functions the discrete/continuous optimization problem is given by Mixed-integer nonlinear programming (MINLP) model:

$$\begin{aligned}
 \min Z &= f(x, y) \\
 \text{s.t. } g(x, y) &\leq 0 \\
 x &\in X, \quad y \in Y \\
 X &= \{x \mid x \in R^n, x^L \leq x \leq x^U, Bx \leq b\} \\
 Y &= \{y \mid y \in \{0, 1\}^m, Ay \leq a\}
 \end{aligned}
 \tag{MINLP}$$

where $f(x, y)$ and $g(x, y)$ are assumed to be convex, differentiable and bounded over X and Y . The set X is generally assumed to be a compact convex set, and the discrete set Y is a polyhedral of integer points. Usually, in most applications it is assumed that $f(x, y)$ and $g(x, y)$ are linear in the binary variables y .

A recent review of MINLP solution algorithms can be found in Grossmann (2002). Algorithms for the solution of problem (MINLP) include the Branch and Bound (BB) method, which is a direct extension of the linear case of MILPs (Gupta and Ravindran, 1985; Borchers and Mitchell, 1994; Leyffer, 2001). The Branch-and-cut method by Stubbs and Mehrotra (1999), which corresponds to a generalization of the lift and project cuts by Balas, Ceria, and Cornuejols (1993), adds cutting planes to the NLP subproblems in the search tree. Generalized Benders Decomposition (GBD) (Geoffrion, 1972) is an extension of Benders decomposition and consists of solving an alternating sequence of NLP (fixed binary variables) and aggregated MILP master problems that yield lower bounds. The Outer-Approximation (OA) method (Duran and Grossmann, 1986; Yuan et al., 1988; Fletcher and Leyffer, 1994) also consists of solving NLP subproblems and MILP master problems. However, OA uses accumulated function linearizations which act as linear supports for convex functions, and yield stronger lower bounds than GBD that uses accumulated Lagrangian functions that are parametric in the binary variables. The LP/NLP based branch and bound method by Quesada and Grossmann (1992) integrates LP and NLP subproblems of the OA method in one search tree, where the NLP subproblem is solved if a new integer solution is found and the linearization is added to the all the open nodes. Finally the Extended Cutting Plane (ECP) method by Westerlund and Pettersson (1995) is based on an extension of Kelley's cutting plane (1960) method for convex NLPs. The ECP method also solves successively an MILP master problem but it does not solve NLP subproblems as it simply adds successive linearizations at each iteration.

3. Generalized disjunctive programming

In recent years the following major approaches have emerged for solving discrete/continuous optimization problems with logic-based techniques: Generalized Disjunctive Programming (GDP) (Raman and Grossmann, 1994), Mixed Logic Linear Programming (MLLP) (Hooker and Osorio, 1999), and Constraint Programming (CP) (Hentenryck,

1989) The motivations for these logic-based modeling has been to facilitate the modeling, reduce the combinatorial search effort, and improve the handling the nonlinearities. In this paper we will concentrate on Generalized Disjunctive Programming. A general review of logic-based optimization can be found in Hooker (2000).

Generalized Disjunctive Programming (GDP) (Raman and Grossmann, 1994) is an extension of disjunctive programming (Balas, 1979) that provides an alternate way of modeling (MILP) and (MINLP) problems. The general formulation of a (GDP) is as follows:

$$\begin{aligned}
 \min Z &= \sum_{k \in K} c_k + f(x) \\
 \text{s.t. } g(x) &\leq 0 \\
 \bigvee_{j \in J_k} &\left[\begin{array}{l} Y_{jk} \\ h_{jk}(x) \leq 0 \\ c_k = \gamma_{jk} \end{array} \right], k \in K \\
 \Omega(Y) &= \text{True} \\
 x \in R^n, \quad c &\in R^m, \quad Y \in \{\text{true}, \text{false}\}^m
 \end{aligned} \tag{GDP}$$

where Y_{jk} are the Boolean variables that decide whether a given term j in a disjunction $k \in K$ is true or false, and x are the continuous variables. The objective function involves the term $f(x)$ for the continuous variables and the charges c_k that depend on the discrete choices in each disjunction $k \in K$. The constraints $g(x) \leq 0$ must hold regardless of the discrete choice, and $h_{jk}(x) \leq 0$ are conditional constraints that must hold when Y_{jk} is true in the j -th term of the k -th disjunction. The cost variables c_k correspond to the fixed charges, and their value equals to γ_{jk} if the Boolean variable Y_{jk} is true. $\Omega(Y)$ are logical relations for the Boolean variables expressed as propositional logic.

It should be noted that problem (GDP) can be reformulated as an MINLP problem by replacing the Boolean variables by binary variables y_{jk} ,

$$\begin{aligned}
 \min Z &= \sum_{k \in K} \sum_{j \in J_k} \gamma_{jk} y_{jk} + f(x) \\
 \text{s.t. } g(x) &\leq 0 \\
 h_{jk}(x) &\leq M_{jk}(1 - y_{jk}), \quad j \in J_k, \quad k \in K \\
 \sum_{j \in J_k} y_{jk} &= 1, \quad k \in K \\
 Ay &\leq a \\
 0 \leq x &\leq x^U, \quad y_{jk} \in \{0, 1\}, \quad j \in J_k, k \in K
 \end{aligned} \tag{BM}$$

where the disjunctions are replaced by ‘‘Big- M ’’ constraints which involve a parameter M_{jk} and binary variables y_{jk} . The propositional logic statements $\Omega(Y) = \text{True}$ are replaced by the linear constraints $Ay \leq a$ as described by Williams (1985) and Raman and Grossmann (1991). Here we assume that x is a non-negative variable with finite upper

bound x^U . An important issue in model (BM) is how to specify a valid value for the Big-M parameter M_{jk} . If the value is too small, then feasible points may be cut off. If M_{jk} is too large, then the continuous relaxation might be too loose yielding poor lower bounds. Therefore, finding the smallest valid value for M_{jk} is the desired selection. For linear constraints, one can use the upper and lower bound of the variable x to calculate the maximum value of each constraint, which then can be used to calculate a valid value of M_{jk} . For nonlinear constraints one can in principle maximize each constraint over the feasible region, which is a non-trivial calculation.

4. Convex hull relaxation of disjunction

Lee and Grossmann (2000) have derived a convex hull relaxation of problem (GDP). The basic idea is as follows. Consider a disjunction $k \in K$ that has convex constraints,

$$\begin{aligned} & \bigvee_{j \in J_k} \begin{bmatrix} Y_{jk} \\ h_{jk}(x) \leq 0 \\ c = \gamma_{jk} \end{bmatrix} \\ & 0 \leq x \leq x^U, \quad c \geq 0 \end{aligned} \quad (\text{DP})$$

where $h_{jk}(x)$ are assumed to be convex and bounded over x . The convex hull relaxation of disjunction (DP), which is an extension of the work by Stubbs and Mehrotra (1999), is given as follows:

$$\begin{aligned} x &= \sum_{j \in J_k} v^{jk}, \quad c = \sum_{j \in J_k} \lambda_{jk} \gamma_{jk} \\ 0 &\leq v^{jk} \leq \lambda_{jk} x_{jk}^U, \quad j \in J_k \\ \sum_{j \in J_k} \lambda_{jk} &= 1, \quad 0 \leq \lambda_{jk} \leq 1, \quad j \in J_k \\ \lambda_{jk} h_{jk}(v^{jk}/\lambda_{jk}) &\leq 0, \quad j \in J_k \\ x, c, v^{jk} &\geq 0, \quad j \in J_k \end{aligned} \quad (\text{CH})$$

where v^{jk} are disaggregated variables that are assigned to each term of the disjunction $k \in K$, and λ_{jk} are the weight factors that determine the feasibility of the disjunctive term. Note that when λ_{jk} is 1, then the j 'th term in the k 'th disjunction is enforced and the other terms are ignored. The constraints $\lambda_{jk} h_{jk}(v^{jk}/\lambda_{jk})$ are convex if $h_{jk}(x)$ is convex as discussed on p. 160 in Hiriart-Urruty and Lemaréchal (1993). A formal proof can be found in Stubbs and Mehrotra (1999). Note that the convex hull (CH) reduces to the result by Balas (1985) if the constraints are linear. Based on the convex hull relaxation (CH), Lee and Grossmann (2000) proposed the following convex relaxation

program of (GDP).

$$\begin{aligned}
 \min Z^L &= \sum_{k \in K} \sum_{j \in J_k} \gamma_{jk} \lambda_{jk} + f(x) \\
 \text{s.t. } g(x) &\leq 0 \\
 x &= \sum_{j \in J_k} v^{jk}, \quad \sum_{j \in J_k} \lambda_{jk} = 1, \quad k \in K \\
 0 &\leq v^{jk} \leq \lambda_{jk} x^U, \quad j \in J_k, \quad k \in K \\
 \lambda_{jk} h_{jk}(v^{jk}/\lambda_{jk}) &\leq 0, \quad j \in J_k, \quad k \in K \\
 A\lambda &\leq a \\
 0 &\leq x, \quad v^{jk} \leq x^U, \quad 0 \leq \lambda_{jk} \leq 1, \quad j \in J_k, \quad k \in K
 \end{aligned} \tag{CRP}$$

where x^U is a valid upper bound for x and v . For computational reasons, the nonlinear inequality is written as $\lambda_{jk} h_{jk}(v^{jk}/(\lambda_{jk} + \varepsilon)) \leq 0$ where ε is a small tolerance*. Note that the number of constraints and variables increases in (CRP) compared with problem (GDP). Problem (CRP) has a unique optimal solution and it yields a valid lower bound to the optimal solution of problem (GDP) (Lee and Grossmann, 2000). Problem (CRP) can also be regarded as a generalization of the relaxation proposed by Ceria and Soares (1999) for a special form of problem (GDP).

As proved by Grossmann and Lee (2003) problem (CRP) has the useful property that the lower bound is greater than or equal to the lower bound predicted from the relaxation of problem (BM). The relaxation problem (CRP) can be used as a subproblem to construct a disjunctive branch and bound method to solve problem (GDP) (Lee and Grossmann, 2000), which exploits the tight lower bound of the convex hull relaxation program when compared with the Big-M MINLP formulation.

5. Solution algorithms for GDP

For the linear case of problem (GDP) Beaumont (1991) proposed a branch and bound method which directly branches on the constraints of the disjunctions where no logic constraints are involved. Also for the linear case Raman and Grossmann (1994) developed a branch and bound method which solves GDP problem in hybrid form, by exploiting the tight relaxation of the disjunctions and the tightness of the well-behaved mixed-integer constraints. Another approach for solving a linear GDP is to replace the disjunctions either by Big-M constraints or by the convex hull of each disjunction (Balas, 1985; Raman and Grossmann, 1994)

For the nonlinear case a similar way for solving the problem (GDP) is to reformulate it into the MINLP by restricting the variables λ_{jk} in problem (CRP) to 0–1 values. Alternatively, to avoid introducing a potentially large number of variables and constraints, the GDP might also be reformulated as the MINLP problem (BM) by using Big-M

*See Sawaya and Grossmann (2005) for a rigorous approximation.

parameters. One can then apply standard MINLP solution algorithms (i.e., branch and bound, OA, GBD, and ECP). In order to strengthen the lower bounds one can derive cutting planes using the convex hull relaxation (CRP). To generate a cutting plane at iteration n , the following separation problem (SP), which is a convex NLP, is solved:

$$\begin{aligned}
 \min \phi(x) &= (x - x_R^{BM,n})^T (x - x_R^{BM,n}) \\
 \text{s.t. } g(x) &\leq 0 \\
 x &= \sum_{i \in D_k} v_{ik}, \quad k \in K \\
 y_{ik} h_{ik}(v_{ik}/y_{ik}) &\leq 0, \quad i \in D_k, \quad k \in K \\
 \sum_{i \in D_k} y_{ik} &= 1, \quad k \in K \\
 Ay &\leq a \\
 x, v_{ik} &\in R^n, \quad 0 \leq y_{ik} \leq 1
 \end{aligned} \tag{SP}$$

where $x_R^{BM,n}$ is the solution of problem (BM) with relaxed $0 \leq y_{ik} \leq 1$. Problem (SP) yields a solution point x^* which belongs to the convex hull of the disjunction and is closest to the relaxation solution $x_R^{BM,n}$. The most violated cutting plane is then given by,

$$(x^* - x_R^{BM,n})^T (x - x^*) \geq 0 \tag{1}$$

The cutting plane in (1) is a facet of the linearized convex hull and thus, a valid inequality for problem (GDP). Problem (BM) is modified by adding the cutting plane (1) as follows:

$$\begin{aligned}
 \min Z &= \sum_{k \in K} \sum_{i \in D_k} \gamma_{ik} y_{ik} + f(x) \\
 \text{s.t. } g(x) &\leq 0 \\
 h_{ik}(x) &\leq M_{ik}(1 - y_{ik}), \quad i \in D_k, \quad k \in K \\
 \sum_{i \in D_k} y_{ik} &= 1, \quad k \in K \\
 Ay &\leq a \\
 \beta^T x &\leq b \\
 x &\in R^n, \quad 0 \leq y_{ik} \leq 1
 \end{aligned} \tag{CP}$$

where $\beta^T x \leq b$ is the cutting plane (1). Since we add a valid inequality to problem (BM), the lower bound obtained from problem (CP) is generally tighter than before adding the cutting plane.

This procedure for generating the cutting plane can be used either in a Branch and Cut enumeration method where a special case is to solve the separation problem (SP) only at the root node, or else it can be used to strengthen the MINLP problem (BM) before applying methods such as OA, GBD, and ECP. It is also interesting to note that

cutting planes can be derived in the (x, y) space, especially when the objective function has binary variables y .

Another application of the cutting plane is for a decision if it is advantageous to use the convex hull formulation for a relaxation of disjunction. If the value of $\|x^* - x_R^{BM,n}\|$ is large, then it is an indication that this is the case. A small difference between x^* and $x_R^{BM,n}$ would indicate that it might be better to simply use the Big-M relaxation. It should be noted that Sawaya and Grossmann (2005) have recently performed a comprehensive study of cutting planes for linear GDP problems.

There are also direct approaches for solving problem (GDP). In particular, a disjunctive branch and bound method can be developed which directly branches on the term in a disjunction using the convex hull relaxation (CRP) as a basic subproblem (Lee and Grossmann, 2000). Problem (CRP) is solved at the root node of the search tree. The branching rule is to select the least infeasible term in a disjunction first. We can then consider a dichotomy where we fix the value $\lambda_{jk} = 1$ for the disjunctive term that is closest to being satisfied, and consider on the other hand the convex hull of the remaining terms ($\lambda_{jk} = 0$).

When all the decision variables λ_{jk} are fixed, problem (CRP) yields an upper bound to problem (GDP). The optimal solution is the best upper bound after closing the gap between the lower and the upper bound. The proposed algorithm has obviously finite convergence since the number of the terms in the disjunction is finite. Also, since the nonlinear functions are convex, each subproblem has a unique optimal solution. Therefore, the rigorous validity of the bounds is guaranteed.

6. Disjunctive branch and bound example

For the illustration of the disjunctive branch and bound algorithm described at the end of Section 5, we present the following GDP problem with one disjunction:

$$\begin{aligned}
 \min Z &= (x_1 - 3)^2 + (x_2 - 2)^2 + c \\
 \text{s.t.} & \left[\begin{array}{c} Y_1 \\ (x_1)^2 + (x_2)^2 - 1 \leq 0 \\ c = 2 \end{array} \right] \vee \left[\begin{array}{c} Y_2 \\ (x_1 - 4)^2 + (x_2 - 1)^2 - 1 \leq 0 \\ c = 1 \end{array} \right] \\
 & \vee \left[\begin{array}{c} Y_3 \\ (x_1 - 2)^2 + (x_2 - 4)^2 - 1 \leq 0 \\ c = 3 \end{array} \right] \\
 0 \leq x_1, \quad x_2 \leq 8, \quad c \geq 0, \quad Y_j \in \{\text{true}, \text{false}\}, \quad j = 1, 2, 3.
 \end{aligned} \tag{2}$$

There are three terms in the disjunction, and exactly one of them must hold. The feasible set of disjunction (2) and its convex hull are given by three disconnected circles as seen in figure 1. The convex hull of the feasible set is shown in gray area. The optimal solution of is 1.172, $Y^* = (\text{false}, \text{true}, \text{false})$ and $x^* = (3.293, 1.707)$. By using 0-1

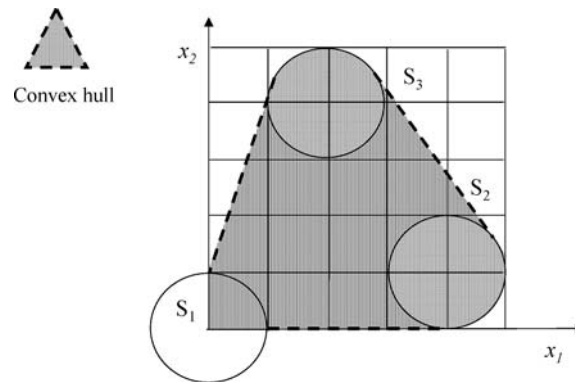

Figure 1. Feasible set and convex hull of Example 1.

variables y_j , GDP problem (2) can be reformulated as an MINLP problem (BM) with Big-M constraints:

$$\begin{aligned}
 \min \quad & Z = (x_1 - 3)^2 + (x_2 - 2)^2 + 2y_1 + y_2 + 3y_3 \\
 \text{s.t.} \quad & (x_1)^2 + (x_2)^2 - 1 \leq M(1 - y_1) \\
 & (x_1 - 4)^2 + (x_2 - 1)^2 - 1 \leq M(1 - y_2) \\
 & (x_1 - 2)^2 + (x_2 - 4)^2 - 1 \leq M(1 - y_3) \\
 & y_1 + y_2 + y_3 = 1 \\
 & 0 \leq x_1, \quad x_2 \leq 8, \quad y_1, \quad y_2, \quad y_3 \in \{0, 1\}, \quad M = 30
 \end{aligned} \tag{3}$$

If $y_1 = 1$, then the first inequality constraint is enforced and if $y_1 = 0$, it becomes redundant assuming that M is a sufficiently large number. If the binary variables y_j are treated as continuous variables in the MINLP problem (3), then for $M = 30$ the relaxed MINLP problem of (3) has the optimal solution of 1.031 and $y^* = (0.029, 0.97, 1, 0)$. The (CRP) model of the GDP problem (2) is as follows:

$$\begin{aligned}
 \min \quad & Z^L = (x_1 - 3)^2 + (x_2 - 2)^2 + 2\lambda_1 + \lambda_2 + 3\lambda_3 \\
 \text{s.t.} \quad & x_1 = v_1^1 + v_1^2 + v_1^3 \\
 & x_2 = v_2^1 + v_2^2 + v_2^3 \\
 & 0 \leq v_i^j \leq 8\lambda_j, \quad i = 1, 2; \quad j = 1, 2, 3. \\
 & \lambda_1 + \lambda_2 + \lambda_3 = 1 \\
 & \lambda_1 \left[\left(\frac{v_1^1}{\lambda_1 + \varepsilon} \right)^2 + \left(\frac{v_2^1}{\lambda_1 + \varepsilon} \right)^2 - 1 \right] \leq 0 \\
 & \lambda_2 \left[\left(\frac{v_1^2}{\lambda_2 + \varepsilon} - 4 \right)^2 + \left(\frac{v_2^2}{\lambda_2 + \varepsilon} - 1 \right)^2 - 1 \right] \leq 0 \\
 & \lambda_3 \left[\left(\frac{v_1^3}{\lambda_3 + \varepsilon} - 2 \right)^2 + \left(\frac{v_2^3}{\lambda_3 + \varepsilon} - 4 \right)^2 - 1 \right] \leq 0 \\
 & 0 \leq x_1, \quad x_2 \leq 8, \quad 0 \leq \lambda_1, \lambda_2, \lambda_3 \leq 1, \quad \varepsilon = 0.0001 \\
 & v_i^j \geq 0, \quad i = 1, 2; \quad j = 1, 2, 3.
 \end{aligned} \tag{4}$$

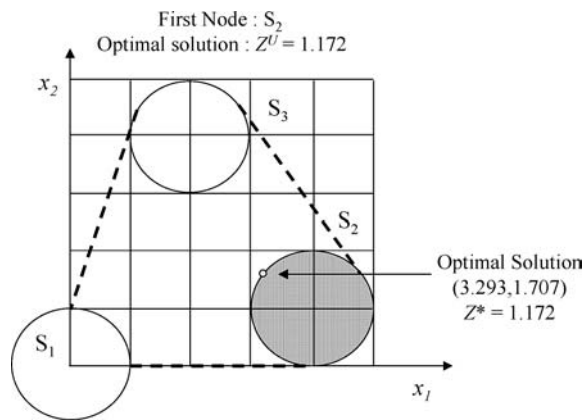

Figure 2. Feasible set at the first node.

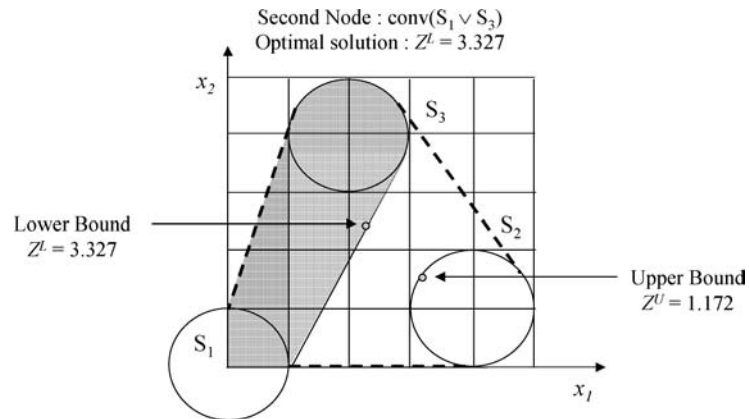

Figure 3. Feasible set at the second node.

To avoid division by zero in the nonlinear constraints, ε is introduced as a small tolerance ($\varepsilon = 0.0001$). The optimal solution of problem (4) is 1.154 and $x^L = (3.195, 1.797)$. Notice that the lower bound (1.154) is tighter than the relaxed solution of MINLP problem (3) (1.031). It should be noted that the convex hull NLP (4) has more variables and constraints than Big-M problem (3). Therefore, the tighter lower bound comes with the price of increased model size and possibly longer CPU time.

In the disjunctive branch and bound method, λ_j will be used in deciding which Boolean variable should be selected at the next node in the search tree. Figures 2 and 3 shows the feasible sets of the subproblems in the search tree. At the root node, problem (4) yields a lower bound $Z^L = 1.154$. This solution point x^L lies outside the feasible region of GDP problem (2) since x^L does not satisfy any term in the disjunction. In the solution λ_2 has the largest value, so we set Y_2 as true. At the first node, the GDP problem

is solved with fixed $Y = (false, true, false)$. It means that we fix λ_2 as 1 and other λ_j as 0 in problem (4). Therefore, the feasible region is restricted to S_2 only as shown in figure 2. Solving GDP problem (2) with $Y_2 = true$ yields an upper bound $Z^U = 1.172$. Since S_2 has been examined, it is removed from the convex hull. At the second node, we consider the convex hull of S_1 and S_3 . By solving problem (4) with $\lambda_2 = 0$, a lower bound $Z^L = 3.327$ is obtained (see figure 3). Since this lower bound 3.327 is greater than the upper bound $Z^U = 1.172$, the feasible solution of S_1 and S_3 will be greater than $Z^L = 3.327 > Z^U = 1.172$. Hence, the optimal solution is $Z^U = 1.172$ and the search ends after 3 nodes.

7. Decomposition of GDP

Türkay and Grossmann (1996) have proposed a logic-based OA algorithm for the case when problem (GDP) involves only two terms in each disjunction ($|J_k| = 2$). The idea is to decompose the problem into NLP and MILP subproblems. For fixed values of the Boolean variables, $Y_{jk} = true$ and $Y_{ik} = false$ for $j \neq i$, the corresponding NLP subproblem is derived from (GDP) as follows:

$$\begin{aligned}
 \min Z &= \sum_{k \in K} c_k + f(x) \\
 \text{s.t. } &g(x) \leq 0 \\
 &\left. \begin{aligned} h_{jk}(x) &\leq 0 \\ c_k &= \gamma_{jk} \end{aligned} \right\} \text{ for } Y_{jk} = true, \quad j \in J_k, \quad k \in K & \quad \text{(NLPD)} \\
 &\left. \begin{aligned} B^i x &= 0 \\ c_k &= 0 \end{aligned} \right\} \text{ for } Y_{ik} = false, \quad i \in J_k, \quad i \neq j, \quad k \in K \\
 &Ay \leq a \\
 &x \in R^n, \quad c \in R^m
 \end{aligned}$$

For every disjunction k only the constraints corresponding to the Boolean variable Y_{jk} that is true are enforced. Also, fixed charges γ_{jk} are applied to these terms. After K subproblems (NLPD) are solved sets of linearizations $l = 1, \dots, K$ are generated for subsets of terms $L_{jk} = \{l \mid Y_{jk}^l = true\}$, then one can define the following disjunctive OA master problem:

$$\begin{aligned}
 \min Z &= \sum_{k \in K} c_k + \alpha \\
 \text{s.t. } &\left. \begin{aligned} \alpha &\geq f(x^l) + \nabla f(x^l)^T(x - x^l) \\ g(x^l) + \nabla g(x^l)^T(x - x^l) &\leq 0 \end{aligned} \right\} \quad l = 1, \dots, L
 \end{aligned}$$

$$\left[\begin{array}{c} Y_{jk} \\ h_{jk}(x^l) + \nabla h_{jk}(x^l)^T(x - x^l) \leq 0, l \in L_{jk} \\ c_k = \gamma_{jk} \end{array} \right] \vee \left[\begin{array}{c} \neg Y_{jk} \\ B^k x = 0 \\ c_k = 0 \end{array} \right], \quad k \in K \quad (\text{MGDP})$$

$$\Omega(Y) = \text{True}$$

$$x \in R^n, \quad c \in R^m, \quad Y \in \{\text{true}, \text{false}\}^m$$

Before solving the MILP master problem it is necessary to solve various subproblems (NLPD) in order to produce at least one linear approximation of each of the terms in the disjunctions. As shown by Türkay and Grossmann (1996) selecting the smallest number of subproblems amounts to the solution of a set covering problem. In the context of flowsheet synthesis problems, another way of generating the linearizations in (MGDP) is by starting with an initial flowsheet and optimizing the remaining subsystems as in the modeling/decomposition strategy (Kocis and Grossmann, 1987).

Problem (MGDP) can be solved by the methods described by Beaumont (1991), Raman and Grossmann (1994), and Hooker and Osorio (1999). For the case of process networks, Türkay and Grossmann (1996) have shown that if the convex hull representation of the disjunctions in (MGDP) is used, then assuming $B^k = I$ and converting the logic relations $\Omega(Y)$ into the inequalities $Ay \leq a$, leads to the MILP reformulation of (NLPD) which can be solved with OA. Türkay and Grossmann (1996) have also shown that while a logic-based Generalized Benders method (Geoffrion, 1972) cannot be derived as in the case of the OA algorithm, one can exploit the property for MINLP problems that performing one Benders iteration (Türkay and Grossmann, 1996) on the MILP master problem of the OA algorithm, is equivalent to generating a Generalized Benders cut. Therefore, a logic-based version of the Generalized Benders method performs one Benders iteration on the MILP master problem. Also, slack variables can be introduced to problem (MGDP) to reduce the effect of nonconvexity as in the augmented-penalty MILP master problem (Viswanathan and Grossmann, 1990).

8. Hybrid GDP/MINLP

Vecchiotti and Grossmann (1999) have proposed a hybrid formulation of the GDP and algebraic MINLP models. It involves disjunctions and mixed-integer constraints as follows:

$$\begin{aligned} \min Z &= \sum_{k \in K} c_k + f(x) + d^T y \\ \text{s.t. } g(x) &\leq 0 \\ r(x) + Dy &\leq 0 \\ Ay &\leq a \end{aligned} \quad (\text{PH})$$

$$j \in J_k \left[\begin{array}{c} Y_{jk} \\ h_{jk}(x) \leq 0 \\ c_k = \gamma_{jk} \end{array} \right], k \in K$$

$$\Omega(Y) = True$$

$$x \in R^n, \quad c \in R^m, \quad y \in \{0, 1\}^q, \quad Y \in \{true, false\}^m$$

where x and c are continuous variables and Y and y are discrete variables. Note that problem (PH) can reduce to a GDP problem or to an MINLP problem, depending on the absence and presence of the mixed-integer constraints and disjunctions and logic propositions. Thus, problem (PH) provides the flexibility of modeling an optimization problem as a GDP, MINLP or a hybrid model, making it possible to exploit the advantage of each model.

An extension of the logic-based OA algorithm for solving problem (PH) has been implemented in LOGMIP, a computer code based on GAMS (Vecchietti and Grossmann, 1999). This algorithm decomposes problem (PH) into two subproblems, the NLP and the MILP master problems. With fixed discrete variables, the NLP subproblem is solved. Then at the solution point of the NLP subproblem, the nonlinear constraints are linearized and the disjunction is relaxed by convex hull to build a master MILP subproblem which will yield a new discrete choice of (y, Y) for the next iteration.

9. Process network example

This example was originally proposed by Duran and Grossmann (1986) as an MINLP problem, and later Türkay and Grossmann (1996) formulated it as a GDP problem. Figure 4 shows the superstructure which has 8 possible processes.

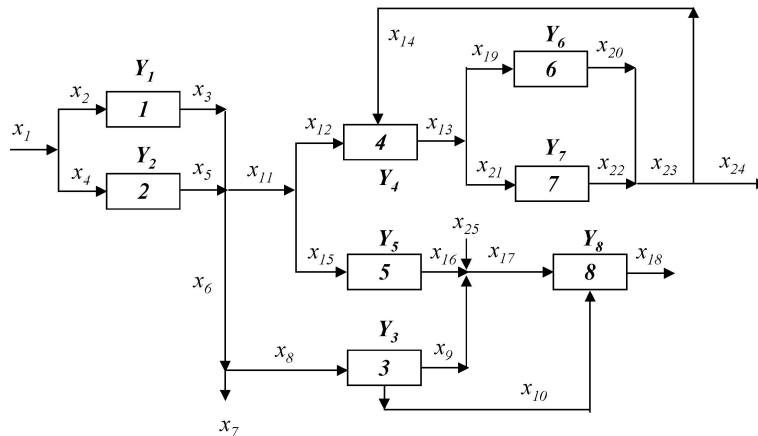

Figure 4. Superstructure for process network example.

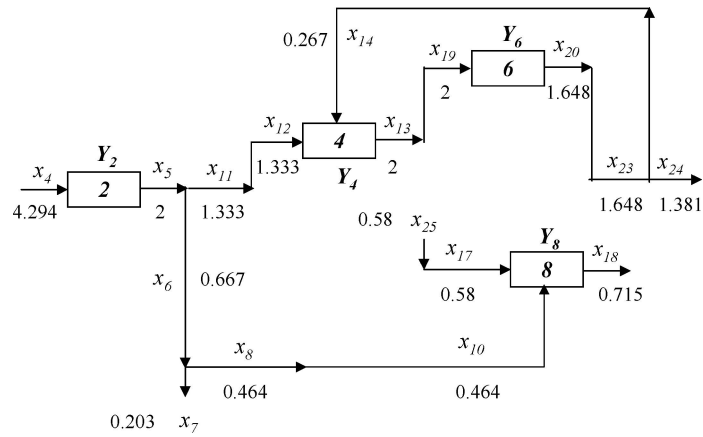

Figure 5. The optimal plant structure.

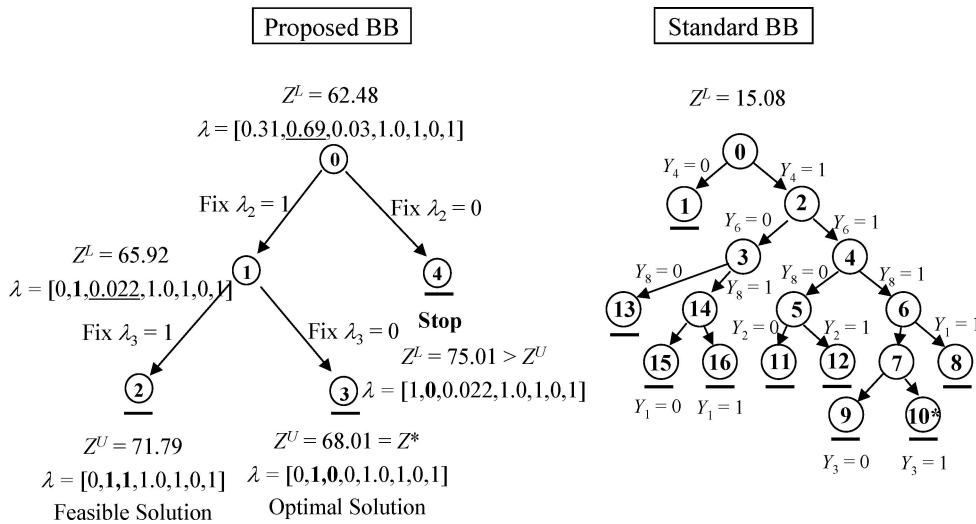

Figure 6. Comparison of branch and bound methods.

is 68.01 and it consists of processes 2, 4, 6, and 8 as shown in figure 5. The GDP model has eight disjunctions for the processes, mass balances, and propositional logic for the relationship of these units. For the GDP model formulation, see Türkay and Grossmann (1996).

As seen in figure 6, the disjunctive branch and bound (BB) algorithm by Lee and Grossmann (2000) finds the optimal solution in only 5 nodes compared with 17 nodes of standard branch and bound method when applied to the relaxed MINLP formulation (BM). A major difference in these two methods is the lower bound predicted by the

relaxed NLP. Clearly the bound at the root node in the disjunctive BB method, which is given by problem (CRP), is much stronger than the relaxed solution of problem (BM) (62.48 vs. 15.08). This shows that the logic-based formulation (GDP) yields a tight relaxation that can be exploited by a disjunctive branch and bound method. On the other hand it is clear that there exists a trade-off between problems (BM) and (CRP) in terms of problem size and tightness of the lower bound. As in this example the tight lower bound of (CRP) helped to reduce the number of nodes in the branch and bound tree, although (BM) is smaller in size and likely to be solved faster.

10. Global optimization algorithm

In the previous sections of the paper we have assumed convexity in the nonlinear functions. However, in many applications nonlinearities give rise to nonconvex functions. Nonlinear programs which involve nonconvex functions may yield local solutions, not guaranteeing the global optimality. Global optimization of nonconvex programs has received increased attention due to the practical importance of solving nonlinear optimization problems. Most of the deterministic global optimization algorithms are based on spatial branch and bound algorithm (Horst and Tuy, 1996). The spatial branch and bound method divides the feasible region of continuous variables and compares lower bound and upper bound for fathoming each subregion. The subregion that contains the optimal solution is found by eliminating subregions that are proved not to contain the optimal solution.

For nonconvex NLP problems, Quesada and Grossmann (1995) proposed a spatial branch and bound algorithm for concave separable, linear fractional and bilinear programs using of linear and nonlinear underestimating functions (McCormick, 1976). For nonconvex MINLP, Ryoo and Sahinidis (1995) and later Tawarmalani and Sahinidis (2000a) have developed BARON, which branches on the continuous and discrete variables with bounds reduction method. Adjiman, Androulakis, and Floudas (1997, 2000) proposed the SMIN- α BB and GMIN- α BB algorithms for twice-differentiable nonconvex MINLPs. By using a valid convex underestimation of general functions as well as for special functions, Adjiman et al. (1996) developed the α BB method which branches on both the continuous and discrete variables according to specific options. The branch-and-contract method (Zamora and Grossmann, 1999) has bilinear, linear fractional, and concave separable functions in the continuous variables and binary variables, uses bound contraction and applies the outer-approximation (OA) algorithm at each node of the tree. Kesavan and Barton (2000) developed a generalized branch-and-cut (GBC) algorithm, and recently extended the OA algorithm to nonconvex separable problems (Kesavan et al., 2004). Also, Smith and Pantelides (1997) proposed a reformulation method combined with a spatial branch and bound algorithm for nonconvex MINLP and NLP, which is implemented in the gPROMS modeling system.

11. Nonconvex GDP

We briefly describe a global optimization algorithm proposed by Lee and Grossmann (2001) for the case when the problem (GDP) involves bilinear, linear fractional and concave separable functions. First, these nonconvex functions of continuous variables are relaxed by replacing them with underestimating convex functions (McCormick, 1976; Quesada and Grossmann, 1995). Next, the convex hull of each nonlinear disjunction is constructed to build a convex NLP problem (CRP). Figure 7 shows the proposed global optimization procedure. At the first step, an upper bound is obtained by solving the nonconvex MINLP reformulation (BM) with the OA algorithm. This upper bound is then used for the bound contraction (step 2). The feasible region of continuous variables is contracted with an optimization subproblem that incorporates the valid underestimators and the upper bound value and that minimizes or maximizes each variable in turn. The tightened convex GDP problem is then solved in the first level of a two-level branch and bound algorithm, in which a discrete branch and bound search (see Section 6) is performed on the disjunctions to predict lower bounds. In the second level, a spatial branch and bound method is used to solve nonconvex NLP problems for updating the upper bound. The proposed algorithm exploits the convex hull relaxation for the discrete search, and the fact that the spatial branch and bound is restricted to fixed discrete variables in order to predict tight lower bounds.

We present an illustrative nonconvex GDP example which was originally proposed as a nonconvex MINLP by Kocis and Grossmann (1989) for optimizing a small superstructure consisting of two reactors. Lee and Grossmann (2001) reformulated this

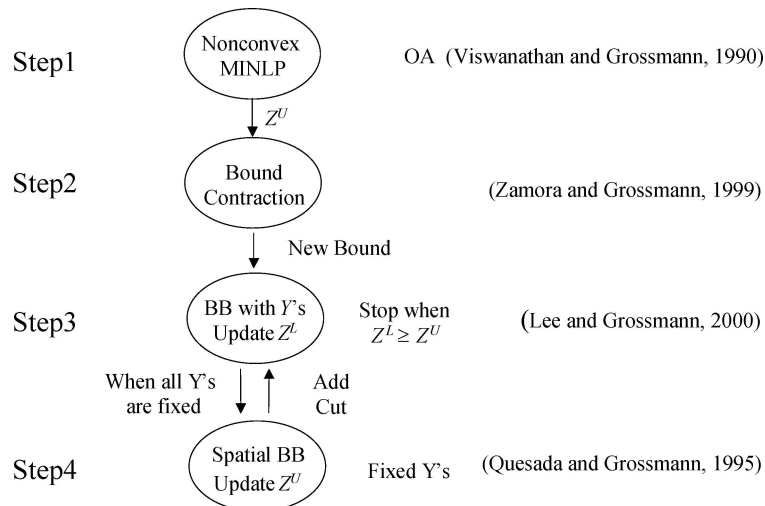

Figure 7. Global optimization algorithm for nonconvex GDP.

Table 1
Numerical results of illustrative example.

Step method	Step 1 outer approximation	Step 2 bound contraction	Step 3 discrete branch and bound	Step 4 spatial branch and bound
Result	First UB = 99.2	63.5% reduction	First LB = 97.5	1 SBB/UB = 99.2
Iter./Nodes	3 Iter.	4 Iter. (NLPs)	2 Nodes (NLPs)	5 Nodes (NLPs)

problem as the following nonconvex GDP problem:

$$\begin{aligned}
 & \min Z = c + 5x + p \\
 & \text{s.t.} \left[\begin{array}{c} Y_1 \\ 10 = 0.9[1 - \exp(-0.5v)]x \\ p = 7.0v \\ c = 7.5 \end{array} \right] \vee \left[\begin{array}{c} Y_2 \\ 10 = 0.8[1 - \exp(-0.4v)]x \\ p = 6.0v \\ c = 5.5 \end{array} \right] \quad (5) \\
 & 0 \leq v \leq 10; \quad 0 \leq x \leq 20; \quad 0 \leq c, p
 \end{aligned}$$

The optimal solution is 99.2 with $Y^* = (\text{true}, \text{false})$, $x^* = 13.4$ and $v^* = 3.5$. Problem (5) has nonconvex constraints in the disjunction. The global optimization algorithm by Lee and Grossmann (2001) is applied to problem (5) and its solution results are shown in Table 1. In step 1, a nonconvex MINLP reformulation (BM) is solved with the OA method. An initial upper bound of 99.2 is obtained after 3 major iterations. To derive the convex relaxation we first substitute $[1 - \exp(-0.5v)]$ in the first term with the continuous variable α , resulting in bilinear terms. The nonlinear equality $\alpha = [1 - \exp(-0.5v)]$ is replaced by two nonlinear inequalities.

$$\begin{aligned}
 & \min Z = c + 5x + p \\
 & \text{s.t.} \left[\begin{array}{c} Y_1 \\ 10 = 0.9\alpha x \\ \alpha \leq [1 - \exp(-0.5v)] \\ \alpha \geq [1 - \exp(-0.5v)] \\ p = 7.0v \\ c = 7.5 \end{array} \right] \vee \left[\begin{array}{c} Y_2 \\ 10 = 0.8\alpha x \\ \alpha \leq [1 - \exp(-0.4v)] \\ \alpha \geq [1 - \exp(-0.4v)] \\ p = 6.0v \\ c = 5.5 \end{array} \right] \quad (6) \\
 & 0 \leq v \leq 10; \quad 0 \leq x \leq 20; \quad 0 \leq c, p, \alpha
 \end{aligned}$$

The bilinear term αx is replaced by linear under and overestimators (McCormick, 1976). In the first term of the disjunction, the inequality $\alpha \leq [1 - \exp(-0.5v)]$ is convex while the inequality $\alpha \geq [1 - \exp(-0.5v)]$ is concave. We underestimate the concave term by a secant line which matches the concave term at the lower and upper bound of

v . The convex underestimating problem of (6) is then as follows:

$$\begin{aligned}
 & \min Z = c + 5x + p \\
 & \text{s.t.} \quad \left[\begin{array}{c} Y_1 \\ 10/0.9 \geq \alpha_1^U x + \alpha x^U - \alpha_1^U x^U \\ 10/0.9 \geq \alpha_1^L x + \alpha x^L - \alpha_1^L x^L \\ 10/0.9 \leq \alpha_1^U x + \alpha x^L - \alpha_1^U x^L \\ 10/0.9 \leq \alpha_1^L x + \alpha x^U - \alpha_1^L x^U \\ \alpha \leq [1 - \exp(-0.5v)] \\ \alpha \geq \alpha_1^L + (v - v^L) \frac{\alpha_1^U - \alpha_1^L}{v^U - v^L} \\ p = 7.0v \\ c = 7.5 \end{array} \right] \vee \left[\begin{array}{c} Y_2 \\ 10/0.8 \geq \alpha_2^U x + \alpha x^U - \alpha_2^U x^U \\ 10/0.8 \geq \alpha_2^L x + \alpha x^L - \alpha_2^L x^L \\ 10/0.8 \leq \alpha_2^U x + \alpha x^L - \alpha_2^U x^L \\ 10/0.8 \leq \alpha_2^L x + \alpha x^U - \alpha_2^L x^U \\ \alpha \leq [1 - \exp(-0.4v)] \\ \alpha \geq \alpha_2^L + (v - v^L) \frac{\alpha_2^U - \alpha_2^L}{v^U - v^L} \\ p = 6.0v \\ c = 5.5 \end{array} \right] \quad (7) \\
 & 0 \leq v \leq 10; \quad 0 \leq x \leq 20; \quad 0 \leq c, p, \alpha
 \end{aligned}$$

where $\alpha_1^L = 1 - \exp(-0.5v^L)$, $\alpha_1^U = 1 - \exp(-0.5v^U)$, $\alpha_2^L = 1 - \exp(-0.4v^L)$, $\alpha_2^U = 1 - \exp(-0.4v^U)$. The convex hull relaxation of problem (7) results in problem (CRP). In step 1, we solve the bound contraction problem of the continuous variable x and v . Initially, the bounds are $0 \leq x \leq 20$ and $0 \leq v \leq 10$. After solving 4 NLPs, the new bounds are $11.1 \leq x \leq 18.7$ and $1.6 \leq v \leq 5.1$. With the new bounds, the discrete branch and bound is performed in step 3. Figure 8 shows the two-level branch and bound tree. The first lower bound at the root node is 97.5. We relax λ in problem (CRP) as continuous variables between 0 and 1. λ_j corresponds to the Boolean variable Y_j in problem (GDP) and $\lambda_j = 1$ in the solution means $Y_j = \text{true}$. Solving problem (CRP) yields a discrete feasible solution of $\lambda = (1, 0)$. For convenience, we denote this value of λ as Y^L . This integer value is fixed as $Y^F = (1, 0)$ and the upper bound (99.2) is given to the spatial branch and bound step (node S1 in figure 8). In step 4, the branching variables are x and v . The variable with the largest difference in the variable bounds is selected

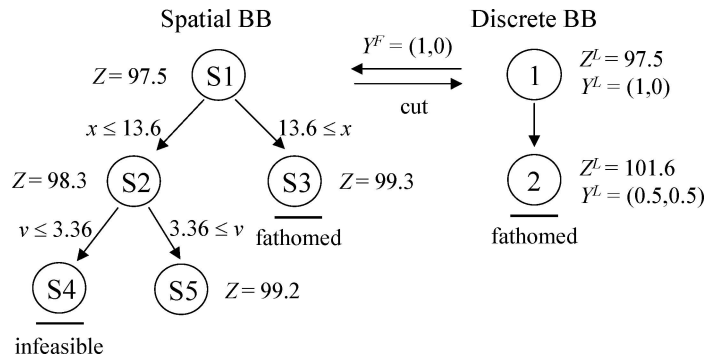

Figure 8. Branch and bound tree for nonconvex GDP example.

Table 2
Numerical results of GDP problems.

Problem number	Problem type	No. of continuous variables	No. of Boolean variable	No. of constraints	Optimal solution	CPU sec
1	Convex	30	25	105	-8.064	2.86
2	Convex	33	8	67	68.01	1.09
3	Convex	184	41	376	261,883	40.91
4	Nonconvex	51	33	102	264,887	47.1
5	Nonconvex	105	53	271	726,205	163.7
6	Nonconvex	312	59	1231	662,590	521.3
7	Nonconvex	52	16	124	74,710	420.6

first. The branching variable and its branching point are shown on each node. At node S1, x is selected first and the branching point is the middle point of the variable bounds. At node S3, the objective value 99.3 is higher than the upper bound, so it is fathomed. Node S4 is infeasible and node S5 yields the optimal solution. 5 NLPs are solved with a relative tolerance of 0.1% and the optimality of the upper bound 99.2 is verified for fixed $Y^F = (1, 0)$. A logic cut is added to node 1 of step 2 and problem (CRP) is resolved since the gap between upper and lower bounds is not closed yet at the node 1. Node 2 yields a solution $Y^L = (0.5, 0.5)$ and $Z^L = 101.6$, and hence it is fathomed by the upper bound and the search is finished.

12. Computational results

A number of GDP problems have been solved by Lee and Grossmann (2000, 2001) and their numerical results are shown in Table 2. These problems were solved with GAMS on a Pentium III PC. The first column and the second column show the problem number and type. The third column shows the number of continuous variables, the fourth column shows the number of Boolean variables, and the fifth column shows the number of constraints, respectively. Problems 1–3 are convex GDP problems and were solved with the disjunctive branch and bound method described in Section 5. Problems 4–7 are nonconvex GDPs and they were solved with the two-level branch and bound algorithm. In all cases, the optimal solution is found in reasonable CPU time as shown in the last column.

13. Conclusion

In this paper, we have presented some of the recent advances in the discrete/continuous optimization models and solution algorithms. Algebraic models such as MILP and MINLP have been widely used in operations research and engineering. An emerging approach

relies on logic-based models which involve logic constraints and disjunctions. The strategy for the relaxation of disjunctions and its properties have been used to develop a disjunctive branch and bound algorithm for GDP problems. Also, the reformulation to MINLP procedure has been presented, as well as a Cutting Plane method for tightening the lower bound in the corresponding Big-M formulation. Global optimization algorithms of nonconvex MINLP/GDP have been also briefly discussed and illustrated with a small example. It is hoped that this review has shown that the logic-based approach to mathematical programming has made substantial progress and offers significant promise in the future.

Acknowledgments

The authors would like to acknowledge financial support from the NSF Grant ACI-0121497 and from the Center for Advanced Process Decision-making at Carnegie Mellon University.

References

- Adjiman, C.S., I.P. Androulakis, C.D. Maranas, and C.A. Floudas. (1996). "A Global Optimization Method, α BB, for Process Design." *Computers and Chem. Engng.* 20, (Suppl.), S419–S424.
- Adjiman, C.S., I.P. Androulakis, and C.A. Floudas. (1997). "Global Optimization of MINLP Problems in Process Synthesis and Design." *Computers and Chem. Engng.* 21, (Suppl.), S445–S450.
- Adjiman, C.S., I.P. Androulakis, and C.A. Floudas. (2000). "Global Optimization of Mixed-Integer Nonlinear Problems." *AIChE Journal* 46(9), 1769–1797.
- Balas, E. (1965). "An Additive Algorithm for Solving Linear Programs with Zero-One Variables." *Operations Research* 13, 517–546.
- Balas, E. (1979). "Disjunctive Programming." *Annals of Discrete Mathematics* 5, 3–51.
- Balas, E. (1985). "Disjunctive Programming and a Hierarchy of Relaxations for Discrete Optimization Problems." *SIAM J. Alg. Disc. Meth.* 6, 466–486.
- Balas, E., S. Ceria, and G. Cornuejols. (1993). "A Lift-and-Project Cutting Plane Algorithm for Mixed 0-1 Programs." *Mathematical Programming* 58, 295–324.
- Beaumont, N. (1991). "An Algorithm for Disjunctive Programs." *European Journal of Operations Research* 48, 362–371.
- Benders, J.F. (1962). "Partitioning Procedures for Solving Mixed Variables Programming Problems." *Numerische Mathematik* 4, 238–252.
- Borchers, B. and J.E. Mitchell. (1994). "An Improved Branch and Bound Algorithm for Mixed Integer Nonlinear Programming." *Computers and Operations Research* 21, 359–367.
- Ceria, S. and J. Soares. (1999). "Convex Programming for Disjunctive Optimization," *Mathematical Programming* 86(3), 595–614.
- Crowder, H.P., E.L. Johnson, and M. W. Padberg. (1983) "Solving Large-Scale Zero-One Linear Programming Problems." *Operations Research* 31, 803–834.
- Dakin, R.J. (1965). "A Tree Search Algorithm for Mixed Integer Programming Problems." *Computer Journal* 8, 250–255.
- Duran, M.A. and I.E. Grossmann. (1986). "An Outer-Approximation Algorithm for a Class of Mixed-Integer Nonlinear Programs." *Mathematical Programming* 36, 307–339.

- Fletcher, R. and S. Leyffer. (1994). "Solving Mixed Nonlinear Programs by Outer Approximation." *Mathematical Programming* 66(3), 327–349.
- Geoffrion, A.M. (1972). "Generalized Benders Decomposition." *Journal of Optimization Theory and Application* 10(4), 237–260.
- Gomory, R.E. (1958). "Outline of an Algorithm for Integer Solutions to Linear Programs." *Bulletin of the American Mathematics Society* 64, 275–278.
- Grossmann, I.E. (2002). "Review of Nonlinear Mixed-Integer and Disjunctive Programming Techniques for Process Systems Engineering." *Journal of Optimization and Engineering* (submitted to) 2002.
- Grossmann, I.E., J.P. Caballero, and H. Yeomans. (1999). "Mathematical Programming Approaches to the Synthesis of Chemical Process Systems." *Korean Journal of Chemical Engineering* 16(4), 407–426.
- Grossmann, I.E. and S. Lee. (2003). "Generalized Disjunctive Programming: Nonlinear Convex Hull Relaxation and Algorithms." *Computational Optimization and Applications* 26, 83–100.
- Gupta, O.K. and V. Ravindran. (1985). "Branch and Bound Experiments in Convex Nonlinear Integer Programming." *Management Science* 31(12), 1533–1546.
- Hentenryck, P.V. (1989). *Constraint Satisfaction in Logic Programming*. Cambridge, MA: MIT Press.
- Hiriart-Urruty, J. and C. Lemaréchal. (1993). *Convex Analysis and Minimization Algorithms*. Berlin, New York: Springer-Verlag.
- Hooker, J.N. (2000). *Logic-Based Methods for Optimization*. John Wiley & Sons.
- Hooker, J.N. and M.A. Osorio. (1999). "Mixed logical/linear programming." *Discrete Applied Mathematics* 96–97(1–3), 395–442.
- Horst R. and H. Tuy (1996) *Global Optimization: Deterministic Approaches*, 3rd ed. Springer-Verlag, Berlin.
- Johnson, E.L., G.L. Nemhauser, and M.W.P. Savelsbergh. (2000). "Progress in Linear Programming Based Branch-and-Bound Algorithms: An Exposition." *INFORMS Journal on Computing* 12.
- Kallrath, J. (2000). "Mixed Integer Optimization in the Chemical Process Industry: Experience, Potential and Future." *Trans. I. Chem. E.* 78 (Part A), 809–822.
- Kesavan, P., R.J. Allgor, E.P. Gatzke, and P.I. Barton. (2004). "Outer Approximation Algorithms for Separable Nonconvex Mixed-Integer Nonlinear Programs." *Mathematical Programming* 100, 517–535.
- Kesavan, P. and P.I. Barton. (2000). "Generalized Branch-and-Cut Framework for Mixed-Integer Nonlinear Optimization Problems." *Computers Chem. Engng.* 24, 1361–1366.
- Kelley, Jr. J.E. (1960). "The Cutting-Plane Method for Solving Convex Programs." *Journal of SIAM* 8, 703.
- Kocis, G.R. and I.E. Grossmann. (1987). "Relaxation Strategy for the Structural Optimization of Process Flowsheets." *Ind. Eng. Chem. Res.* 26, 1869.
- Kocis, G.R. and I.E. Grossmann. (1989). "A Modelling and Decomposition Strategy for the MINLP Optimization of Process Flowsheets." *Computers and Chem. Engng.* 13(7), 797–819.
- Land, A.H. and A.G. Doig. (1960). "An Automatic Method for Solving Discrete Programming Problems." *Econometrica* 28, 497–520.
- Lee, S. and I.E. Grossmann. (2000). "New Algorithms for Nonlinear Generalized Disjunctive Programming." *Computers Chem. Engng.* 24, 2125–2141.
- Lee, S. and I.E. Grossmann. (2001). "A Global Optimization Algorithm for Nonconvex Generalized Disjunctive Programming and Applications to Process Systems." *Computers Chem. Engng.* 25, 1675–1697.
- Leyffer, S. (2001). "Integrating SQP and branch-and-bound for Mixed Integer Nonlinear Programming." *Computational Optimization and Applications* 18, 295–309.
- Lovász, L. and A. Schrijver. (1991). "Cones of Matrices and Set-Functions and 0-1 Optimization." *SIAM Journal on Optimization* 12, 166–190.
- McCormick, G.P. (1976). "Computability of Global Solutions to Factorable Nonconvex Programs: Part I – Convex Underestimating Problems." *Mathematical Programming* 10, 147–175.
- Nemhauser, G.L. and L.A. Wolsey. (1988). *Integer and Combinatorial Optimization*. New York: Wiley-Interscience.
- Quesada, I. and I.E. Grossmann. (1992). "An LP/NLP Based Branch and Bound Algorithm for Convex MINLP Optimization Problems." *Computers Chem. Engng.* 16(10/11), 937–947.

- Quesada, I. and I.E. Grossmann. (1995). "A Global Optimization Algorithm for Linear Fractional and Bilinear Programs." *Journal of Global Optimization* 6(1), 39–76.
- Raman, R. and I.E. Grossmann. (1991). "Relation Between MILP Modelling and Logical Inference for Chemical Process Synthesis." *Computers Chem. Engng.* 15(2), 73–84.
- Raman, R. and I.E. Grossmann. (1994). "Modelling and Computational Techniques for Logic Based Integer Programming." *Computers Chem. Engng.* 18(7), 563–578.
- Ryoo, H.S. and N.V. Sahinidis. (1995). "Global Optimization of Nonconvex NLPs and MINLPs with Applications in Process Design." *Computers and Chem. Engng.* 19(5), 551–566.
- Sawaya, N.W. and I.E. Grossmann. (2005). "A Cutting Plane Method for Solving Linear Generalized Disjunctive Programming Problems." *Computers Chem. Engng.* (to appear).
- Sawaya, N.W. and I.E. Grossmann. (2005). "Computational Implementation of Non-Linear Convex Hull Reformulation." Submitted for publication *Computers Chem. Engng.*
- Sherali, H.D. and W.P. Adams. (1990). "A Hierarchy of Relaxations Between the Continuous and Convex Hull Representations for Zero-One Programming Problems." *SIAM Journal on Discrete Mathematics* 3(3), 411–430.
- Smith, E.M.B. and C.C. Pantelides. (1997). "Global Optimization of Nonconvex NLPs and MINLPs with Applications in Process Design." *Computers Chem. Engng.* 21(1001), S791–S796.
- Stubbs, R. and S. Mehrotra. (1999). "A Branch-and-Cut Method for 0-1 Mixed Convex Programming." *Mathematical Programming* 86(3), 515–532.
- Türkay, M. and I.E. Grossmann. (1996). "Logic-based MINLP Algorithms for the Optimal Synthesis of Process Networks." *Computers Chem. Engng.* 20(8), 959–978.
- Van Roy, T.J. and L.A. Wolsey. (1986). "Valid Inequalities for Mixed 0-1 Programs." *Discrete Applied Mathematics* 14, 199–213.
- Vecchiotti, A. and I.E. Grossmann. (1999). "LOGMIP: A Disjunctive 0-1 Nonlinear Optimizer for Process Systems Models." *Computers Chem. Engng.* 23, 555–565.
- Viswanathan, J. and I.E. Grossmann. (1990). "A Combined Penalty Function and Outer-Approximation Method for MINLP Optimization." *Computers Chem. Engng.* 14, 769.
- Yuan, X, S. Zhang, L. Piboleau, and S. Domenech. (1988). "Une Methode d' optimization Nonlineare en Variables Mixtes pour la Conception de Porcedes." *Rairo Recherche Operationnelle* 22, 331.
- Westerlund, T. and F. Pettersson. (1995). "An Extended Cutting Plane Method for Solving Convex MINLP Problems." *Computers Chem. Engng.* 19(supl.), S131–S136.
- Williams, H.P. (1985). *Mathematical Building in Mathematical Programming*. Chichester; John Wiley.
- Zamora, J.M. and I.E. Grossmann. (1999). "A Branch and Bound Algorithm for Problems with Concave Univariate, Bilinear and Linear Fractional Terms." *Journal of Global Optimization* 14(3), 217–249.